

間接型熱風発生装置用途事例

● 鍍金製品乾燥

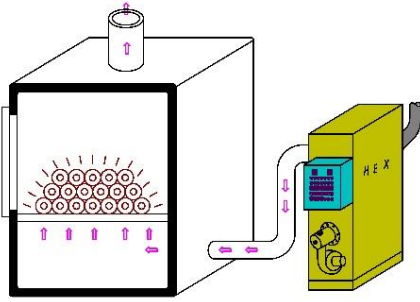

● 鋼線表面処理前予熱

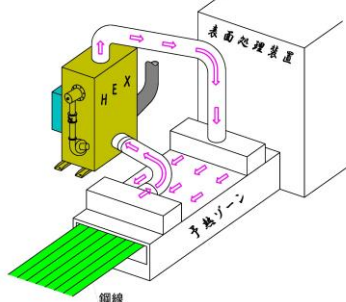

● 液体タンク ● スプレードライヤー

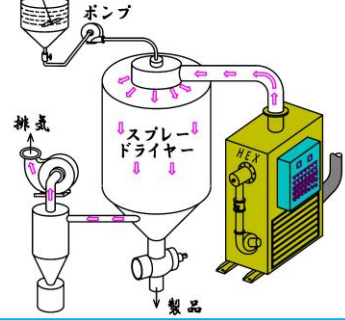

● アルミ製品調質熱処理

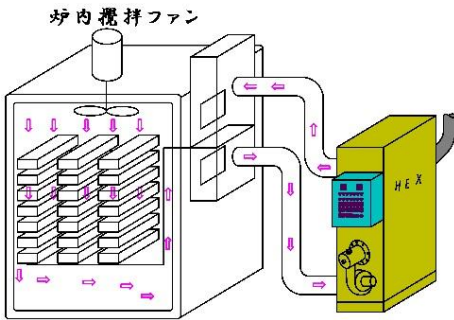

● 番重乾燥

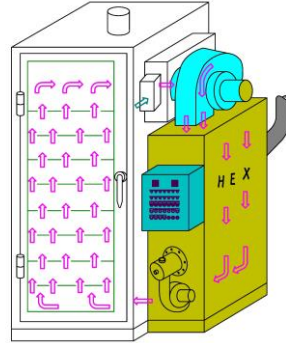

● バッテリー恒温熟成

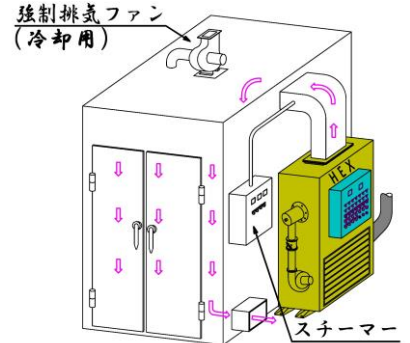

● 蛍光管乾燥

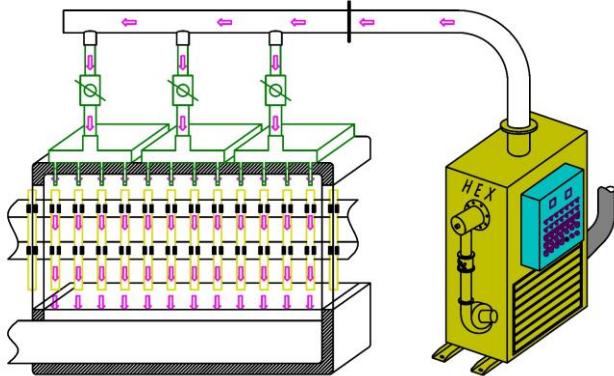

● ビール缶乾燥

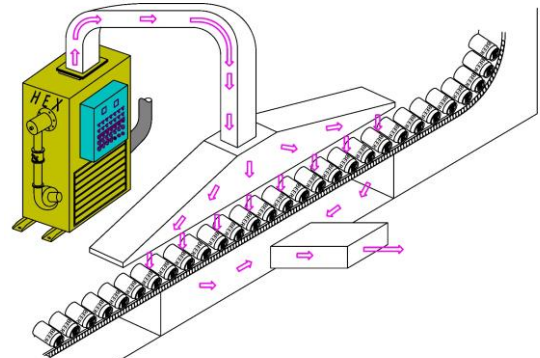

● 砂型乾燥

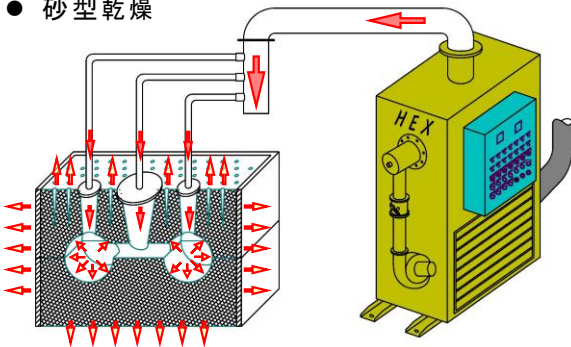

● 工場暖房、恒温

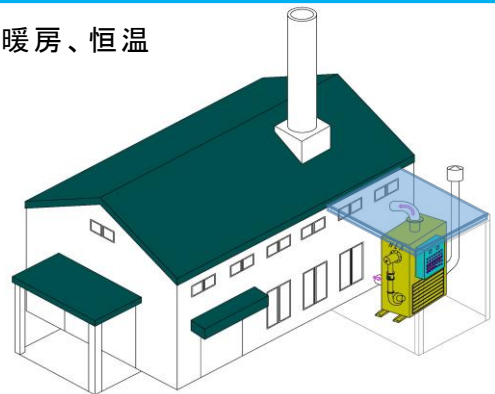

次代の熱テクノロジーを創造し続ける

細山熱器株式会社



本社：〒103-0025 東京都中央区日本橋茅場町2-8-7

TEL:03-3249-0331(代) FAX:03-3249-0329

新潟営業所：〒950-0916 新潟市米山1-5-5

TEL:025-246-0166(代) FAX:025-241-3833

名古屋出張所：〒450-0002 名古屋市中村区名駅5-22-23
第3上善ビル1階

TEL:052-551-1021(代) FAX:052-551-1022(代)

大阪営業所：〒535-0031 大阪市旭区高殿2-7-19

TEL:06-6922-5581(代) FAX:06-6921-2040

福岡営業所：〒815-0033 福岡市南区大橋3-25-1 貞方ビルD号室

TEL:092-403-0255(代) FAX:092-403-0257

間接型熱風発生装置用途事例

● 海苔乾燥

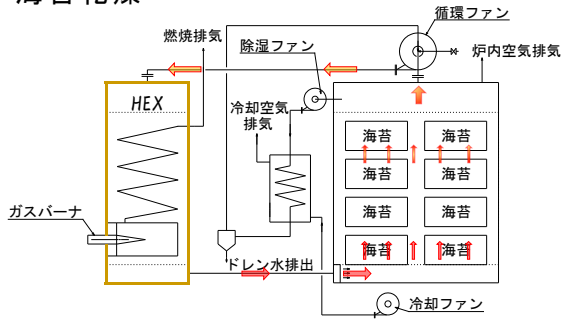

● セラミックボール殺菌乾燥

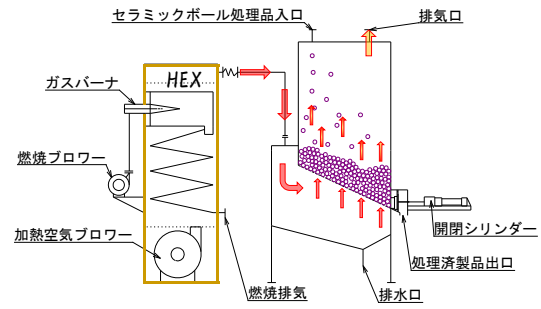

● 澱粉気流乾燥

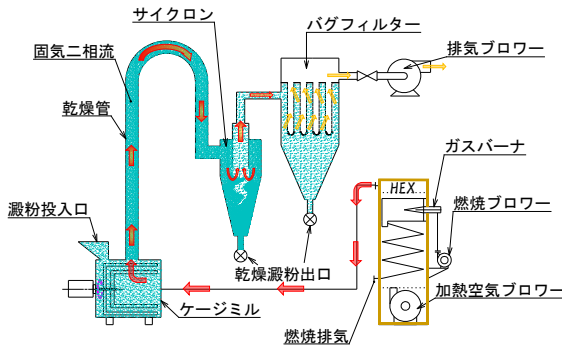

● 塗装物乾燥

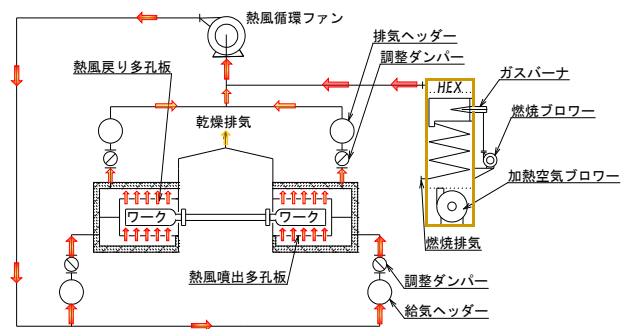

● 流動床式塩乾燥

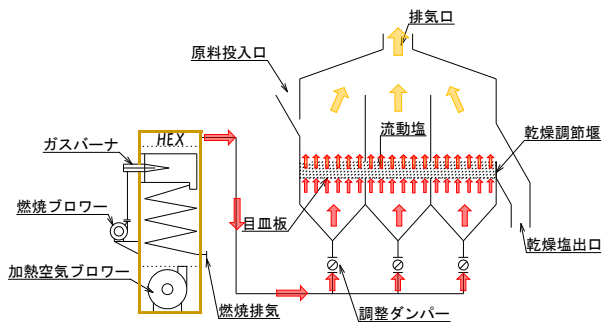

● ゴム製品(風船)乾燥

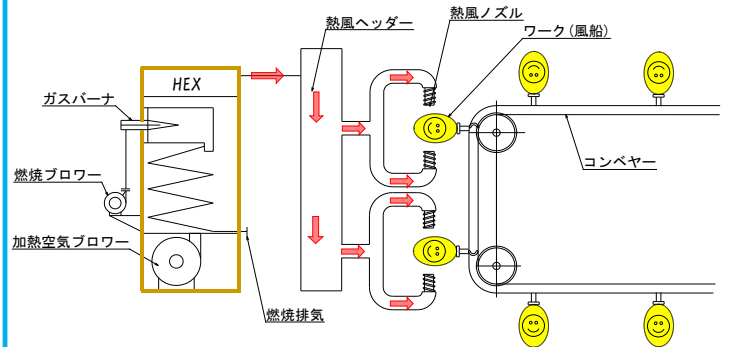

● 加熱炉発生揮発性ガス希釈

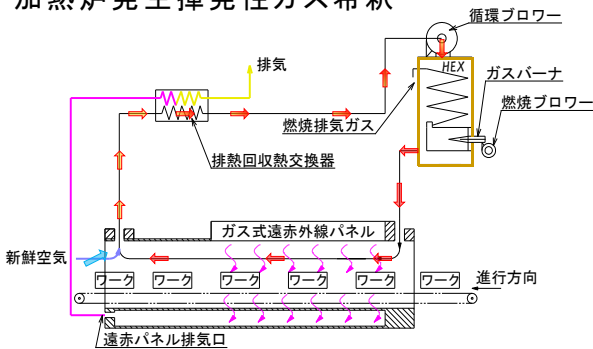

● 焼バメ炉

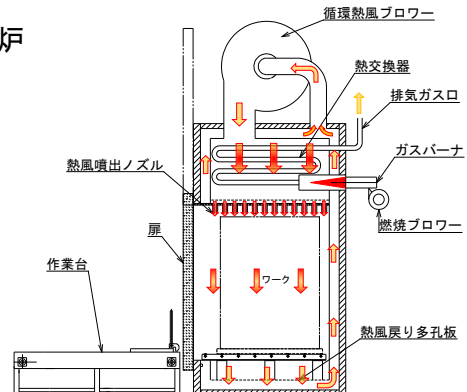

● 熱風循環型焼戻炉

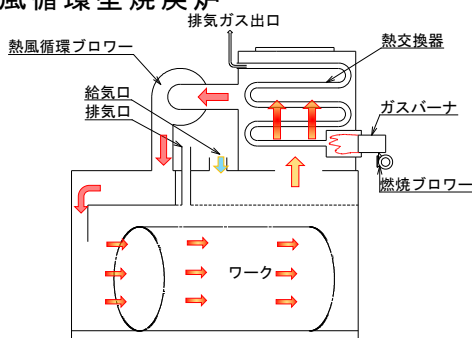

● ワニス含浸後硬化炉

